

INNOVATIVE WORK TECHNOLOGIES USED IN THE ELECTRICAL ENERGY SYSTEM

Choriyev Diyorbek Mansur o'g'li

student

Karshi Engineering and Economic Institute

Abstract

Reliable control of the world electric power system is implemented by innovative electrical devices and technologies. Among such modern technologies, it is possible to include FACTS-Flexible Alternative Current Transmission System devices.

Keywords

FACTS, power system, SSSC, TCSC, SVC, STATCOM, UPFC, IPFC.

It is advisable to use FACTS-Flexible Alternative Current Transmission System (FACTS-Flexible Alternative Current Transmission System). In addition, the task of the FACTS family of devices to improve the management of power flows in the electric power system is considered important. Therefore, the problems of improving and expanding the energy market between the neighboring countries, which currently work in parallel with the electric power system of Uzbekistan, will also find their solution. Currently, the Central Asian United Energy System (BET) is working on the aforementioned issues. Such technologies are effective for both large and small power systems. In addition, the role of FACTS technology is incomparable to solve the problems that arise in providing consumers with reliable and high-quality electricity supply.

FACTS technology is a family of devices, each of which can be used individually or in combination with other devices to control the interrelated parameters of the electric power system. The purpose of FACTS technology is to improve the stable control of power flows in electric power systems. In general, FACTS technology allows taking various corrective actions depending on the conditions of a specific control task and is divided into several types.

FACTS devices perform the following tasks: power flow control, emergency current limiting, voltage adjustment and control, load balancing, increasing the dynamic stability limit, limiting temporary overvoltages, compensating reactive power, increasing the carrying capacity of the EUL line, damping various fluctuations in EET and others.

Thus, SVC, STATCOM and TCSC are used to comply with voltage limits, TCSC, SSSC and UPFC are used for thermal limits, and TCSC, SSSC are used to increase stability. UPFC type is a high performance FACTS device for active and reactive power control, line power conversion, line voltage control in transmission lines.

The following types of FACTS devices are used:

SSSC (Static Synchronous Series Compensator)- Longitudinal static synchronous compensator;

TCSC (Thyristor Controlled Series Capacitor) - thyristor controlled longitudinal capacitor;

SVC(Static Var Compensator)- Static reactive power compensator;
STATCOM(Static Synchronous Compensator)- Static synchronous compensator;
UPFC (Unified Power Flow Controller)- Unified power flow controller;
IPFC (Interline Power Flow Controller)- Interline power flow controller.
Let's look at some of the FACTS family of technologies in connection schemes:

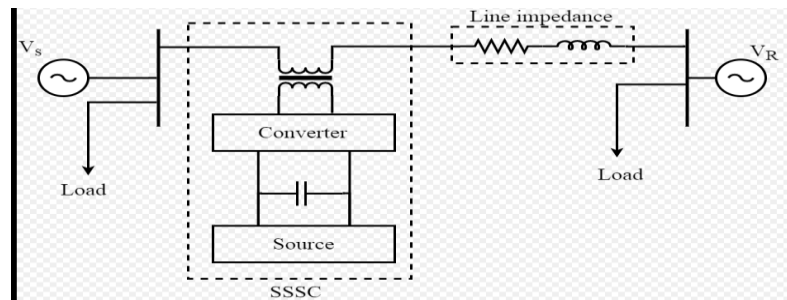

- 1) SSSC (Static Synchronous Series Compensator) - Longitudinal Static Synchronous Compensator

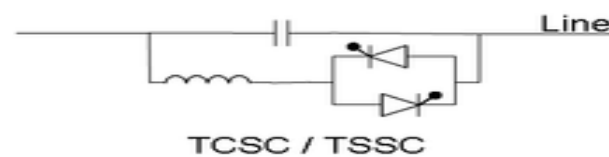
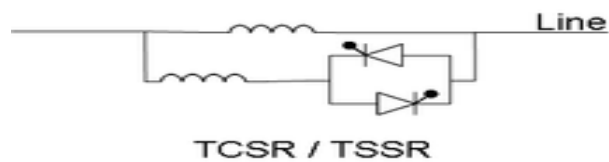

- 2) TCSC (Thyristor Controlled Series Capacitor)

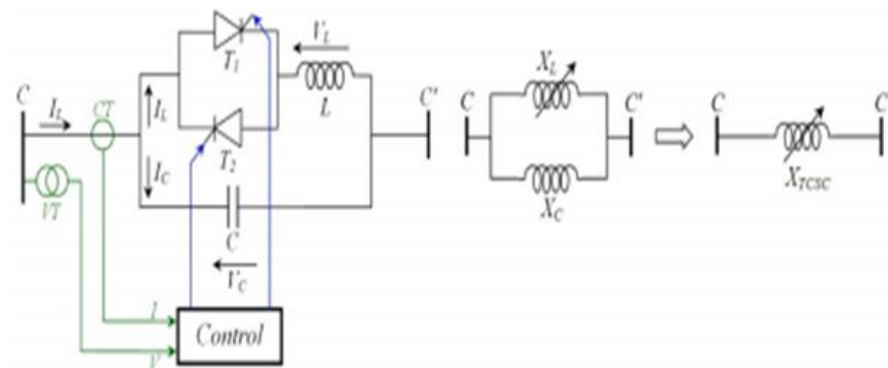

- 3) SVC(Static Var Compensator)

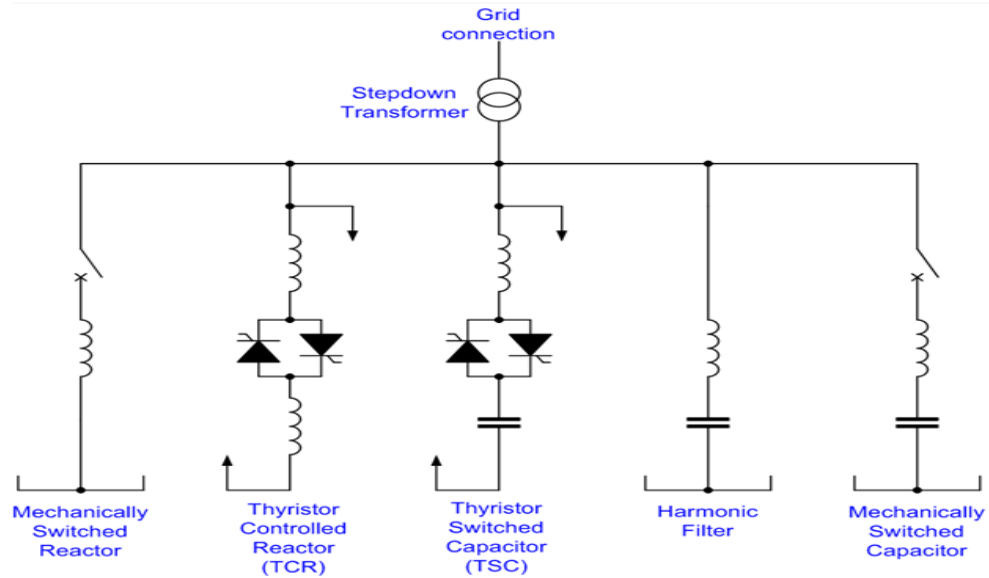

4) STATCOM (Static Synchronous Compensator)

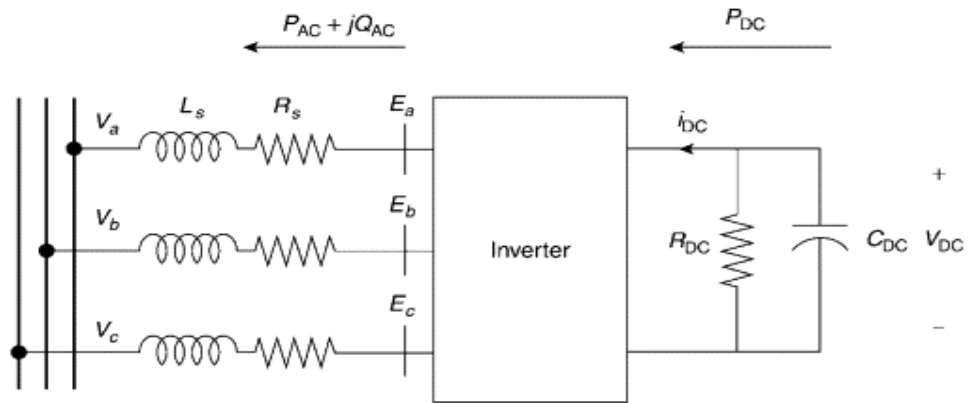

5) UPFC (Unified Power Flow Controller)

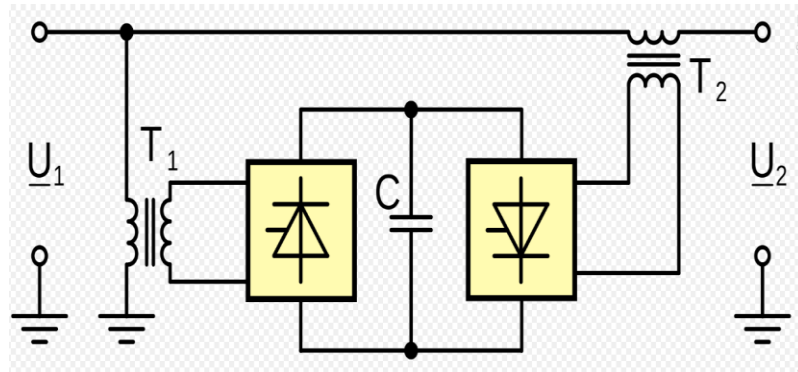

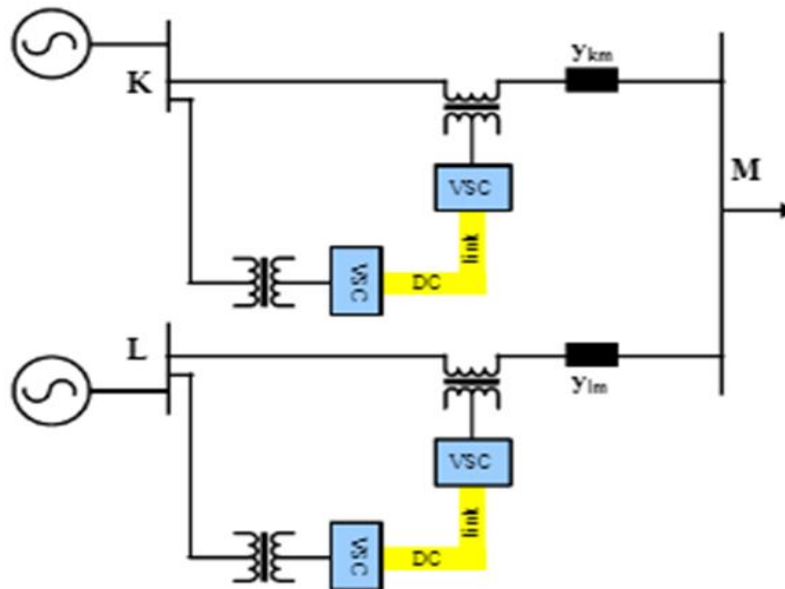

6) IPFC (Interline Power Flow Controller)

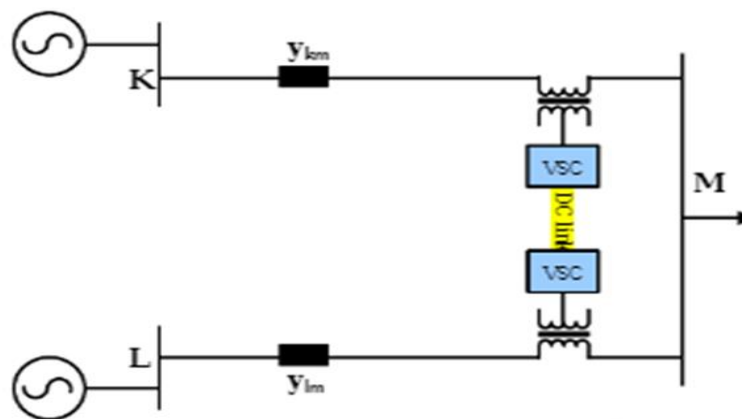

LITERATURE:

1. Shouket, H. A., Ameen, I., Tursunov, O., Kholikova, K., Pirimov, O., Kurbonov, N., ... & Mukimov, B. (2020, December). Study on industrial applications of papain: A succinct review. In *IOP Conference Series: Earth and Environmental Science* (Vol. 614, No. 1, p. 012171). IOP Publishing.

2. Turdiboyev, A., Aytbaev, N., Mamutov, M., Tursunov, A., Toshev, T., & Kurbonov, N. (2023, March). Study on application of electrohydraulic effect for disinfection and increase of water nutrient content for plants. In *IOP Conference Series: Earth and Environmental Science* (Vol. 1142, No. 1, p. 012027). IOP Publishing.

3. Abdullayevich, Q. N. (2023). EFFICIENCY OF USE OF FREQUENCY CONVERTER WITH SMOOTH CONTROL OF ASYNCHRONOUS MOTOR SPEED. *Galaxy International Interdisciplinary Research Journal*, 11(5), 448-449.

4. Abdullayevich, Q. N. (2023). Ways to Reduce Losses in Power Transformers. *Texas Journal of Engineering and Technology*, 20, 36-37.

5. Abdullayevich, Q. N., & Elmurodovich, B. O. (2023). ПРОВЕДЕНИЕ ЛАБОРАТОРНЫХ ЗАНЯТИЙ ПО ЭЛЕКТРИЧЕСКИМ СХЕМАМ. *Новости образования: исследование в XXI веке*, 1(7), 1006-1010.

6. Abdullayevich, Q. N. (2023). REDUCING ELECTRICITY LOSSES IN ELECTRICAL DISTRIBUTION NETWORKS DUE TO MULTICRITERIA OPTIMIZATION OF LINE SECTIONS. *MODELS AND METHODS FOR INCREASING THE EFFICIENCY OF INNOVATIVE RESEARCH*, 3(28), 275-279.

7. Mahmutxonov, S. J., Qurbonov, N., & Babayev, O. (2022). ELEKTR TARMOQLARIDA SIFAT KO 'RSATKICHLARI VA ISROFLAR. *Innovatsion texnologiyalar*, 47, 14-15.

8. Abdullayevich, Q. N. Muzaffar o'g'li, NT (2023). *ASSESSMENT OF THE INFLUENCED FACTORS ON THE INDICATORS OF SPECIFIC ELECTRICITY CONSUMPTION AT INDUSTRIAL ENTERPRISES. FORMATION OF PSYCHOLOGY AND PEDAGOGY AS INTERDISCIPLINARY SCIENCES*, 2(20), 8-10.

9. Abdullayevich, K. N., & Olimjon o'g'li, E. J. (2024). USING CONSUMER-REGULATORS TO EQUALIZATION OF ELECTRICAL ENERGY SYSTEM LOAD SCHEDULE. *JOURNAL OF MULTIDISCIPLINARY BULLETIN*, 7(4), 25-29.

10 Abdullayevich, Q. N. Almardon o'g'li, NA, & Bahodir o'g, QOA (2024). *INFLUENCE OF ELECTRICAL ENERGY QUALITY ON ELECTRICAL ENERGY WASTE. Научный Фокус*, 1(9), 786-789.

11. Abdullayevich, Q. N. (2023). REACTIVE POWER COMPENSATION. *IMRAS*, 6(6), 506-508.

12. Abdullayevich, K. N., & Olimjon o'g'li, E. J. (2024). FUNCTIONS OF FACTS DEVICES WITH INNOVATION TECHNOLOGY IN THE ELECTRICAL ENERGY SYSTEM. *JOURNAL OF ENGINEERING SCIENCES*, 7(5), 12-16.

13. Abdullayevich, K. N., & Olimjon o'g'li, E. J. (2024). МАТЕМАТИЧЕСКАЯ МОДЕЛЬ АВТОМАТИЧЕСКОГО РЕГУЛЯТОРА ВОЗБУЖДЕНИЯ АРВ. *SCIENTIFIC APPROACH TO THE MODERN EDUCATION SYSTEM*, 3(25), 374-379.

14. Abdullayevich, K. N., & Olimjon o'g'li, E. J. (2024). АНАЛИЗ ТЕХНИЧЕСКОГО СОСТОЯНИЯ СИЛОВЫХ АВТОТРАНСФОРМАТОРОВ. *THE THEORY OF RECENT SCIENTIFIC RESEARCH IN THE FIELD OF PEDAGOGY*, 2(21), 45-48.

15. Abdullayevich, K. N., & Olimjon o'g'li, E. J. (2024). АНАЛИЗ ТЕХНИЧЕСКОГО СОСТОЯНИЯ СИЛОВЫХ АВТОТРАНСФОРМАТОРОВ. *THE THEORY OF RECENT SCIENTIFIC RESEARCH IN THE FIELD OF PEDAGOGY*, 2(21), 45-48.

16. Abdullayevich, K. N. (2024). НОРМАТИВНЫЕ ПОТЕРЬ ЭЛЕКТРОЭНЕРГИИ В РАСПРЕДЕЛИТЕЛЬНЫХ СЕТЯХ 10, 6 и 0, 4 кВ. *THE THEORY OF RECENT SCIENTIFIC RESEARCH IN THE FIELD OF PEDAGOGY*, 2(21), 55-60.

17. Abdullayevich, Q. N., Almardon o'g'li, N. A., & Bahodir o'g, Q. O. A. (2024). INFLUENCE OF ELECTRICAL ENERGY QUALITY ON ELECTRICAL ENERGY WASTE. *Научный Фокус*, 1(9), 786-789.

18. Abdullayevich, Q. N., Almardon o'g'li, N. A., & Bahodir o'g, Q. O. A. (2024). ENSURING ELECTRICAL ENERGY QUALITY IN TEXTILE ENTERPRISES. *Научный Фокус*, 1(9), 794-797.

19. Курбонов, Н. А., Халикова, Х. А., & Ньматов, Б. А. О. (2024). ВОПРОСЫ ПАРАЛЛЕЛЬНЫЕ РАБОТЫ ЭНЕРГОСИСТЕМЫ АФГАНИСТАНА, УЗБЕКИСТАНА И ТАДЖИКИСТАНА С УЧЕТОМ НОВОГО СТРОИТЕЛЬСТВА. *Eurasian Journal of Academic Research*, 4(6-1), 37-41.

20. Usmanov, E., Rajabboeva, A., Kurbonov, N., & Kurbanova, K. (2024, June). Operational logic scheme of the sketch base for an educational simulator in the fundamentals of power supply. In *AIP Conference Proceedings* (Vol. 3152, No. 1). AIP Publishing.

21. Abdullayevich, K. N. (2024). ЭНЕРГИЯНИ ТЕЖАШ ВА ЭНЕРГИЯ САМАРАДОРЛИГИ СОҲАСИДА ИННОВАЦИОН ФАОЛИЯТНИ БОШҚАРИШДА ЛОЙИҲА ЁНДАШУВИДАН ФОЙДАЛАНИШ. *THE THEORY OF RECENT SCIENTIFIC RESEARCH IN THE FIELD OF PEDAGOGY*, 2(25), 363-367.

22. Abdullayevich, Q. N., & Muzaffar o'g'li, N. T. (2024). NORMALIZATION MODES OF HYDROGENERATORS. *THE THEORY OF RECENT SCIENTIFIC RESEARCH IN THE FIELD OF PEDAGOGY*, 2(25), 368-371.

23. Abdullayevich, Q. N., & Muzaffar o'g'li, N. T. (2024). FACTORS AFFECTING SPECIFIC ELECTRICITY CONSUMPTION IN INDUSTRIAL ENTERPRISES. *THE THEORY OF RECENT SCIENTIFIC RESEARCH IN THE FIELD OF PEDAGOGY*, 2(25), 372-376.

24. Abdullayevich, K. N. (2024). ЭЛЕКТР ЭНЕРГИЯ СИФАТИНИ ЭЛЕКТР ЭНЕРГИЯ ИСРОФИГА ТАЪСИРИ. *PEDAGOG*, 7(9), 183-188.

25. Abdullayevich, K. N. (2024). ИНТЕЛЛЕКТУАЛЬНЫЙ МОНИТОРИНГ РЕЖИМОВ ЭЛЕКТРИЧЕСКИХ СЕТЕЙ. *Новости образования: исследование в XXI веке*, 3(26), 203-208.

26. Abdullayevich, K. N. (2024). ОЦЕНКА ВЛИЯЮЩИХ ФАКТОРОВ НА ПОКАЗАТЕЛИ УДЕЛЬНОГО РАСХОДА ЭЛЕКТРОЭНЕРГИИ НА ПРОМЫШЛЕННЫХ ПРЕДПРИЯТИИ. *PROSPECTS AND MAIN TRENDS IN MODERN SCIENCE*, 2(13), 531-536.

27. Abdullayevich, K. N. (2024). ANALYSIS AND EVALUATION OF THE EFFECTIVENESS OF ENERGY SAVING IN INDUSTRIAL ENTERPRISES. *SCIENTIFIC APPROACH TO THE MODERN EDUCATION SYSTEM*, 3(28), 75-81.

28. Abdullayevich, Q. N., & Abduzairovna, N. M. (2024). ЭЛЕКТР ТАЪМИНОТИ ТИЗИМИДА РАҚАМЛИ ПОДСТАНЦИЯЛАРДАН ФОЙДАЛАНИШ МАСАЛАЛАРИ. *Eurasian Journal of Academic Research*, 4(9), 71-75.

29. Ixtiyorovich, D. S. (2023). CONDUCTING LABORATORY CLASSES ON ELECTRICAL CIRCUITS. *Научный Фокус*, 1(1), 84-88.

30. Джураев, Ш. И., & Махмудов, Н. Ш. (2023). ДОСТИЖЕНИЕ ЭНЕРГОЭФФЕКТИВНОСТИ МНОГОЭТАЖНЫХ ДОМОВ С ПОМОЩЬЮ ФОТОРЕЛЕ. *European Journal of Interdisciplinary Research and Development*, 15, 55-57.

31. Джураев, Ш. И. (2023). СМЕШАННОЕ СОЕДИНЕНИЕ РЕЗИСТОРОВ. БАЛАНСИРОВКА МОСТА. *Scientific Impulse*, 1(7), 859-861.

32. Mamarasulova, F., Bobojonov, Y., Djurayev, S., & Karimova, N. (2023).

Stimulating environmental protection activities in the energy sector. In *E3S Web of Conferences* (Vol. 461, p. 01099). EDP Sciences.

33. Ixtiyorovich, S. D., & Olimjon o'g'li, E. J. (2024). АСИНХРОННАЯ МАШИНА С ПЕРЕКЛЮЧЕНИЕМ ПОЛЮСОВ. *Новости образования: исследование в XXI веке*, 2(20), 768-772.

34. Makhmutkhanov, S., Akhrom, J., Djurayev, S., & Vozorov, I. (2024, June). Stimulating environmental protection activities in the energy sector. In *AIP Conference Proceedings* (Vol. 3152, No. 1). AIP Publishing.

35. Файзиев, М. М., Ибрагимов, И. И., Джураев, Ш. И., & Мухаммадиев, А. В. У. (2023). ОПРЕДЕЛЕНИЕ ПАРАМЕТРОВ ЛИНИИ ЭЛЕКТРОПЕРЕДАЧ С ПОМОЩЬЮ ПРОГРАММНОМ ОБЕСПЕЧЕНИИ МАТЛАВ SIMULINK. *Наука, техника и образование*, (2 (90)), 23-27.

36. Ixtiyorovich, D. S., & Abdullayevna, X. X. (2023). ANALYSIS AND EVALUATION OF ENERGY SAVING EFFICIENCY IN COCONOMOTAL INDUSTRIAL ENTERPRISES. *Scientific Impulse*, 1(10), 2144-2149.

37. Ixtiyorovich, D. S. (2023). СТАТИЧЕСКИЕ ОПИСАНИЯ ТРЕХФАЗНОГО ТРАНСФОРМАТОРА С УЧЕТОМ ЧУВСТВИТЕЛЬНЫХ ЭЛЕМЕНТОВ. *Новости образования: исследование в XXI веке*, 2(15), 1183-1189.

38. Ixtiyorovich, D. S., & Abdullayevna, X. X. (2023). STABILIZATION OF SINGLE-PHASE LOAD CURRENT IN THREE-PHASE CIRCUITS. *Scientific Impulse*, 1(10), 1811-1813.

39. Beitullaeva, R., Tukhtaev, B., Norboev, A., Nimatov, K., & Djuraev, S. (2023). Analysis of pump operation in common pressure pipelines using the example of the "Chirchik" pumping station. In *E3S Web of Conferences* (Vol. 460, p. 08015). EDP Sciences.

40. Mamarasulova, F., Bobojonov, Y., Djurayev, S., & Karimova, N. (2023). Stimulating environmental protection activities in the energy sector. In *E3S Web of Conferences* (Vol.461, p. 01099). EDP Sciences.

41. Abdullayevich, K. N., O'G'Li, M. F. A., O'G'Li, E. J. O., & O'G'Li, P. A. B. (2024). MARKOV ZANJIRI USULI VA O 'LCHANGAN SHAMOL TEZLIKLARIDAN FOYDALANGAN HOLDA YANGI SHAMOL TEZLIKLARINI BASHORAT QILISH. *Eurasian Journal of Academic Research*, 4(11-2), 7-12.

42. Abdullayevich, K. N., & Abdullayevna, X. X. (2024). EFFECTIVENESS OF USING A FREQUENCY CONVERTER WITH SMOOTH SPEED CONTROL OF AN INDUCTION MOTOR. *Новости образования: исследование в XXI веке*, 3(27), 151-154.

43. Abdullayevich Q. N., Muzaffar o'g'li N. T. NORMALIZATION MODES OF HYDROGENERATORS //THE THEORY OF RECENT SCIENTIFIC RESEARCH IN THE FIELD OF PEDAGOGY. – 2024. – Т. 2. – №. 25. – С. 368-371.